

H3



LORENZO BARROSO

H3

H3

High-speed machine for closing sausages in natural or artificial casings, nettings and bags, full or empty, with an aluminium clip.

Just by pressing the start lever, and without releasing the sausage from the hands, the H3 automatically gathers the casing together, closes it with an aluminium clip and trims off the excess material.

Features:

- Robust construction and stainless components specially treated to withstand the adverse conditions such machines usually work in.
- Fully pneumatic operation.
- Minimum maintenance.
- Our firm provides lubricant ALB-591 in spray and in can, which meet all EU and USA demanded requirements for its use in the Food Industry.

Following our standards, its devices and elements are protected by our own patents. In order to improve the machine, we reserve the right of modifications without prior notice.

Technical data:

Net weight: 28 kg
Operating pressure: 6 bar
Air consumption: 7liters/cycle

Model

H-18
H-540

Range of clips

H-16, H-18, H-21
H-535, H-540, H-545

Accessories:



Automatic knife



Loops

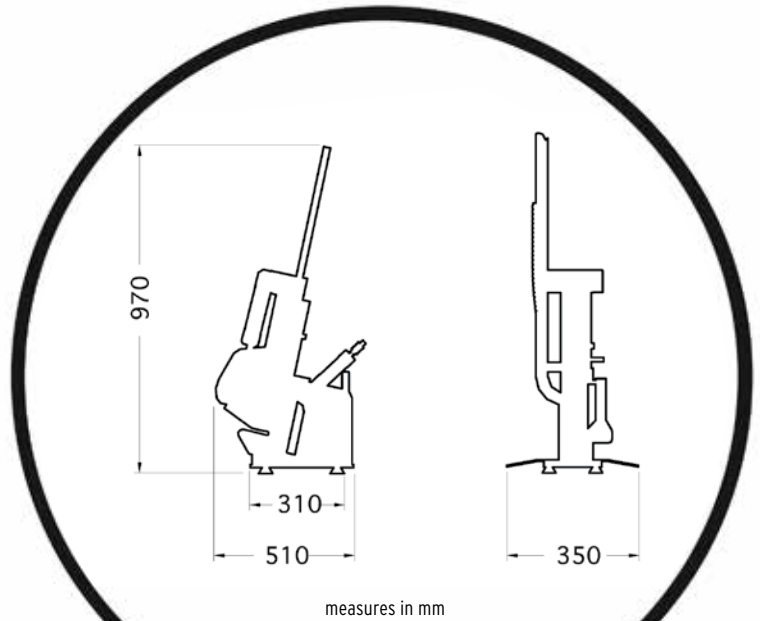

measures in mm



MANUFACTURED BY:

*Images and contents are property of LORENZO BARROSO and any kind of reproduction is forbidden.



LORENZO BARROSO

MANUFACTURER OF MACHINES AND CONSUMABLES SINCE 1958

Pol. Ind. El Cros | C/ Del Torrent de Madà, s/n | ES-08310 Argentona (Barcelona) Spain
Apdo de Correos 73 | P.O. Box 73 | Tel. (+34) 937 998 300 | Fax. (+34) 937 998 288
info@lorenzobarroso.com | www.lorenzobarroso.com