

ALM



LORENZO BARROSO

ALM

ALM

Fully automatic machine for pleating, cutting, and closing with aluminium clips, with or without loops, all kind of tubular nettings and reeled artificial casings.

Computer-controlled; it adapts to a wide range of products by just changing different selected sequences.

Optionally, it can be supplied with other devices for other working options; process of imprinted casings, elastic casings or nets, groups of casings, etc.

High-production machine, specifically designed for casing and netting converters.

Features:

- Robust construction and stainless components specially treated to withstand the adverse conditions such machines usually work in.
- Electropneumatic operation with PLC.
- Minimum maintenance.
- Our firm provides lubricant ALB-591 in spray and in can, which meet all EU and USA demanded requirements for its use in the Food Industry.

Following our standards, its devices and elements are protected by our own patents. In order to improve the machine, we reserve the right of modifications without prior notice.

Technical data:

Net weight: 750 Kg.
Operating pressure: 6 bar
Air consumption: 47 liters/cycle
Electric consumption: 250 W
Electric connection: 50Hz 230V
60Hz 275V

Model

H-3200
C25

Range of clips

HC25-3214, HC25-3216, HC25-3218

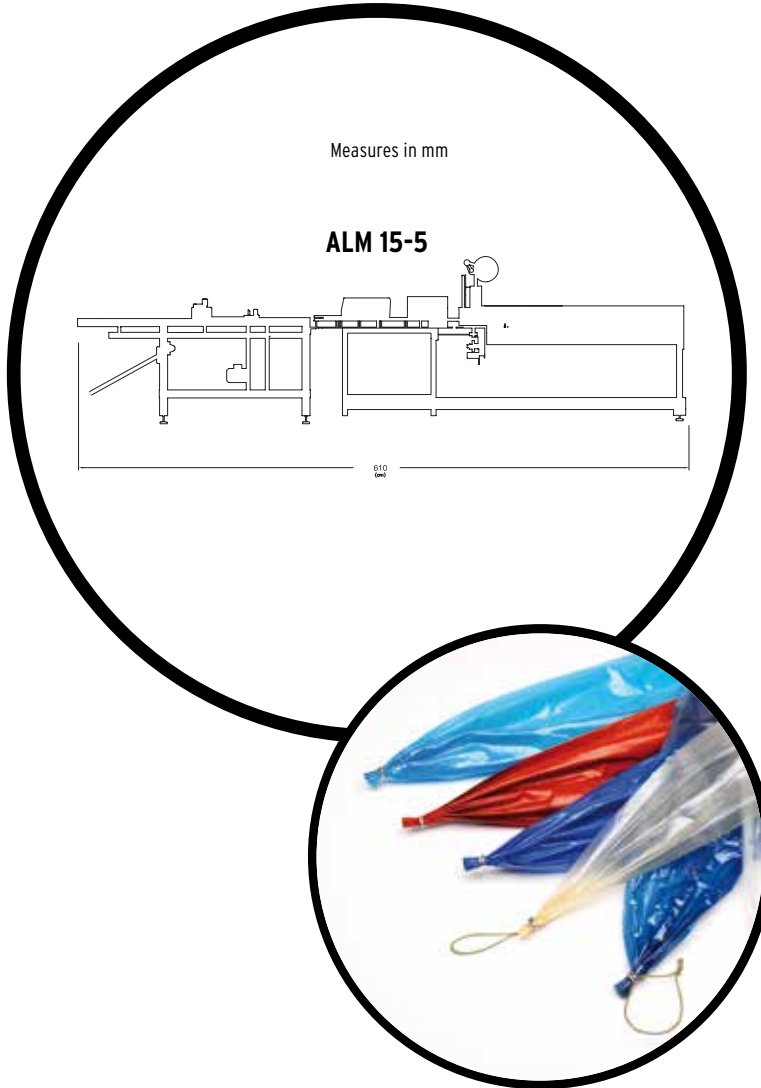

MANUFACTURED BY:



LORENZO BARROSO

MANUFACTURER OF MACHINES AND CONSUMABLES SINCE 1958

Pol. Ind. El Cros | C/ Del Torrent de Madà, s/n | ES-08310 Argentona (Barcelona) Spain
Apdo de Correos 73 | P.O. Box 73 | Tel. (+34) 937 998 300 | Fax. (+34) 937 998 288
info@lorenzobarroso.com | www.lorenzobarroso.com

*Images and contents are property of LORENZO BARROSO and any kind of reproduction is forbidden.